

WS Series Electric Pallet Truck With Lithium Battery Specification

		HANGCHA GROUP CO.,LTD.					
		Model	CBD18-WS-5E	CBD15-WS-6SL	CBD15-WS	CBD20-WS	
Characteristics	1.1 Capacity	kg	2000	1500	1500	2000	
	1.2 Load center	mm	600	600	600	600	
	1.3 Overall fork width	mm	550/685	550/685	520/550/685	550/685	
	1.4 Fork length	mm	1150/1220	1150/1220	1150/1220	1150/1220	
	1.5 Overall length	mm	1552/1622	1552/1622	1552/1622	1552/1622	
	1.6 Overall height of fork	mm	82±2	65±2	82±2	82±2	
	1.7 Max.height of fork	mm	197	165	197	197	
	1.8 Overall height (with tiller)	mm	1276	1250	1276	1276	
	1.9 Rear body width	mm	550/685	550/685	520/550/685	550/685	
	1.10 Minimum turning radius	mm	1353/1426	1353/1426	1353/1426	1353/1426	
Performance	2.1 Max.Traveling speed	laden	km/h	4	4	4	4
		unladen	km/h	5	5	5	5
	2.2 Gradeability	laden	%	6	6	6	6
		unladen	%	20	20	20	20
2.3 Traveling	kw	DC 0.75 Brushless	DC 0.75 Brushless	DC 0.75 Brushless	DC 1.0 Brushless		
2.4 Lifting	kw	Hydraulic	DC 0.8	DC 0.8	DC 0.8		
Battery	4.1 Voltage	v	48	48	48	48	
	4.2 Capacity/type	Ah	10 Ah Lithium	10 Ah Lithium	10 Ah Lithium	10 Ah Lithium	
Brake type	5.1 Travel brake		Regenerate	Regenerate	Regenerate	Regenerate	
	5.2 Brake		Electromagnetic	Electromagnetic	Electromagnetic	Electromagnetic	
Controller	6.1 Controller		B1503	B1503	B1503	B1503	

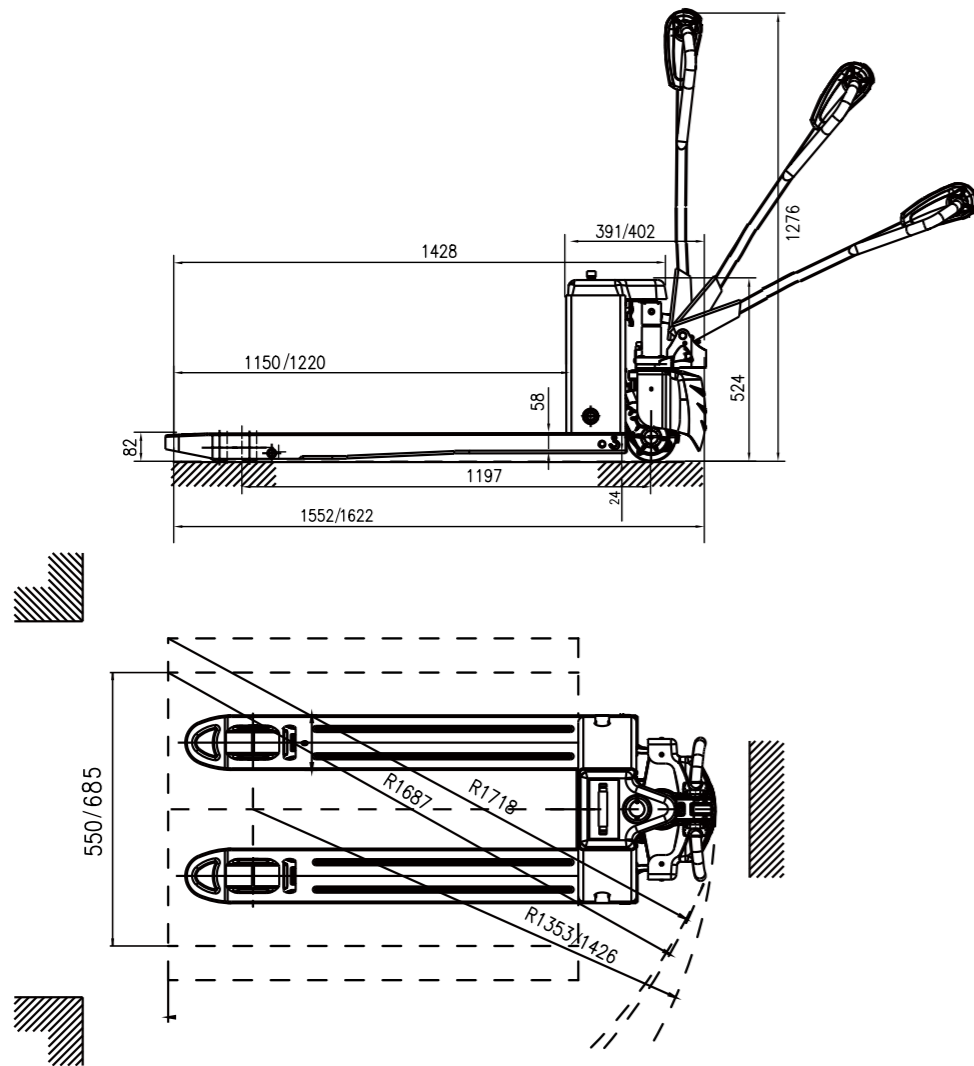

ZHEJIANG HANGCHA IMP. & EXP. CO., LTD.

Factory site: 666 Xiangfu Road,
Hangzhou, Zhejiang, China (311305)

Tel: +86-571-88926735 88926755
Fax: +86-571-88926789 88132890

sales@hcforklift.com
www.hcforklift.com



Follow us on
Facebook



Follow us on
YouTube



Follow us on
WeChat



ISO14001
ISO14001:2015



ISO9001
ISO9001:2015



HANGCHA trucks conform
to the European Safety
Requirements.

HANGCHA GROUP CO., LTD. reserves the right to make any changes without notice concerning colors, equipment, or specifications detailed in this brochure, or to discontinue individual models. The colors of trucks, delivered may differ slightly from those in brochures.



TRANSPALLET A LITIO

1,500/1,800/2,000kg

The World of Hangcha
SINCE 1956



2019 VERSION / COPYRIGHT 2019/12

PERFORMANCE

Velocità di movimento

— SENZA CARICO 5Km/h
 + CON CARICO 4Km/h Full Electric 3.5Km/h Semi-Electric

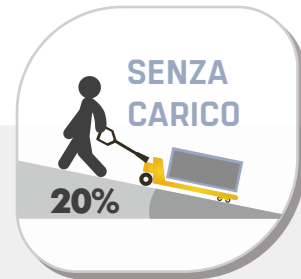

PENDENZA SUPERABILE

FUNZIONI INTELLIGENTI

MODALITA' TRARTARUGA 01



GUIDA CON TIMONE ALZATO 02

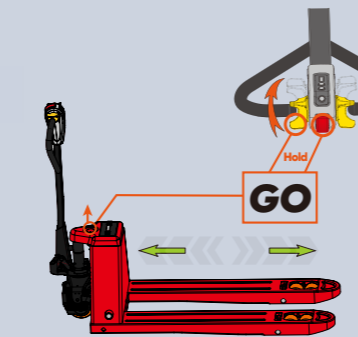

FRENATA RIGENERATIVA 03

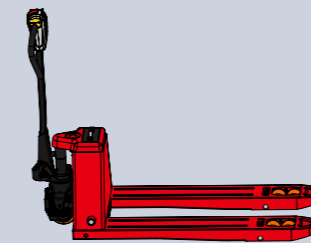

- ⚠ Nella modalità di guida in posizione verticale, il veicolo si muove quando si aziona la maniglia in qualsiasi posizione. Si prega di evitare operazioni errate.
- ⚠ La modalità di rilascio del freno è solo per le emergenze, non consentita per i veicoli in condizioni normali.

CARATTERISTICHE

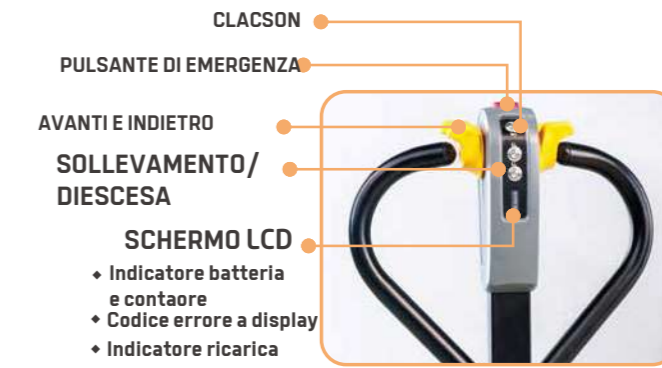

Timone elettrico multifunzione

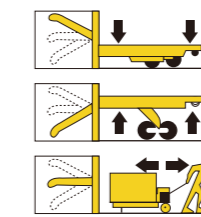

Timone semi-elettrico



CARTER



SISTEMA SOLLEVAMENTO E DISCESA



BATTERIA



SISTEMA BLOCCO BATTERIA

OPTIONS



RULLO SINGOLO O DOPIO RULLO



1.5 AH BATTERIA



CARICATORE RAPIDO (2 ORE)



CHIAVE DI CONTROLLO

COSTRUITO PER LAVORARE 24 ORE

Stesse dimensioni di un transpallet manuale



PESO LEGGERO

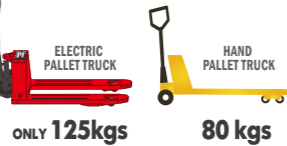

EFFICIENTE

3 VOLTE PIU' EFFICIENTE RISPETTO UN TSM

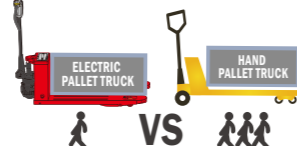

Manutenzione semplice

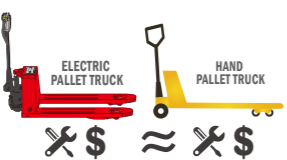

DURABILITA'

3 Volte più durevole di un TSM



MANUTENZIONE COMPLETA

5 anni di garanzia sul telaio



MOTORE AC SENZA SPAZZAOLE

BATTERIA A LITIO SENZA MANUTENZIONE

INDICATORE BATTERIA

DISPLAY PER CODICE ERRORE

6s PER CAMBIO BATTERIA

60s PER CAMBIARE LA RUOTA

TRAZIONE

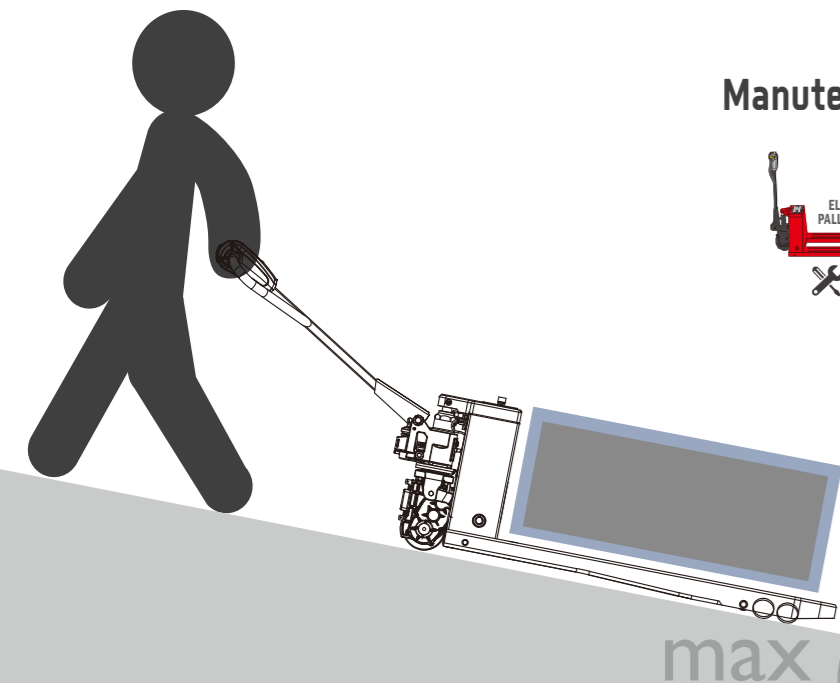

max